

## INSTRUCTION MANUAL

# Oxygen cylinder holder

## IC-A84

7C01948900A3

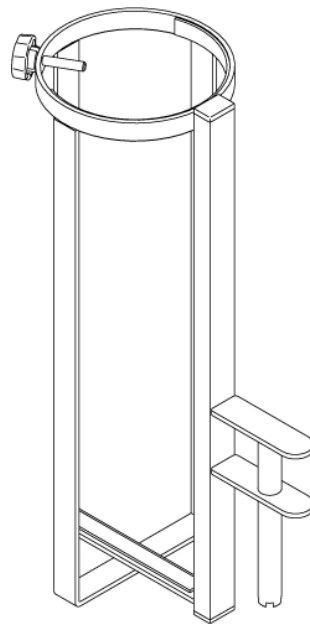

### Preface

Thank you for purchasing the **oxygen cylinder holder**.

This instruction manual describes precautions and how to safely use and operate **the oxygen cylinder holder**.

- **To ensure safe and proper use of the oxygen cylinder holder, be sure to read this instruction manual before use. Also read the instruction manual for the medical device to be used together with this product.**
- In addition to the person who uses the oxygen cylinder holder, caregivers should also read this instruction manual.
- After reading this instruction manual, store it in a place that can be easily accessed for later reference.
- Users and/or patients are requested to report information about any serious incident that occurs within the EU to the regulating authority of the member country of residence.
- Serious incident means any incident that directly or indirectly resulted in, may have resulted in, or may result in any of the following.
  - Death of a patient, user, or other person
  - Serious temporary or permanent adverse effects on the health of a patient, user, or other person
  - Serious public health threat
- Some of the descriptions in this instruction manual may differ from the product you have purchased due to model improvements.
- Description of the operation range, dimensions, angles, and weights are subject to normal manufacturing tolerances. Except for special cases, words such as approximately and about are omitted in this instruction manual to improve readability.
- For any queries, contact Paramount Bed (see P.8) or your distributor.

# INTENDED USE, PART NAMES AND CHECKING PARTS

## Intended use

This oxygen cylinder holder is made for attaching to a medical device to be used together with this product designated by Paramount Bed to use the oxygen cylinder.

[Intended users]  
Medical professionals

[Patient target group]  
Refer to the instruction manual for the medical device to be used together with this product.

## Part names and checking parts

After unpacking, check that there are no missing or damaged parts. If any parts are missing or damaged, contact Paramount Bed (see P.8) or your distributor.

\* For details on the product symbol, see p.7.

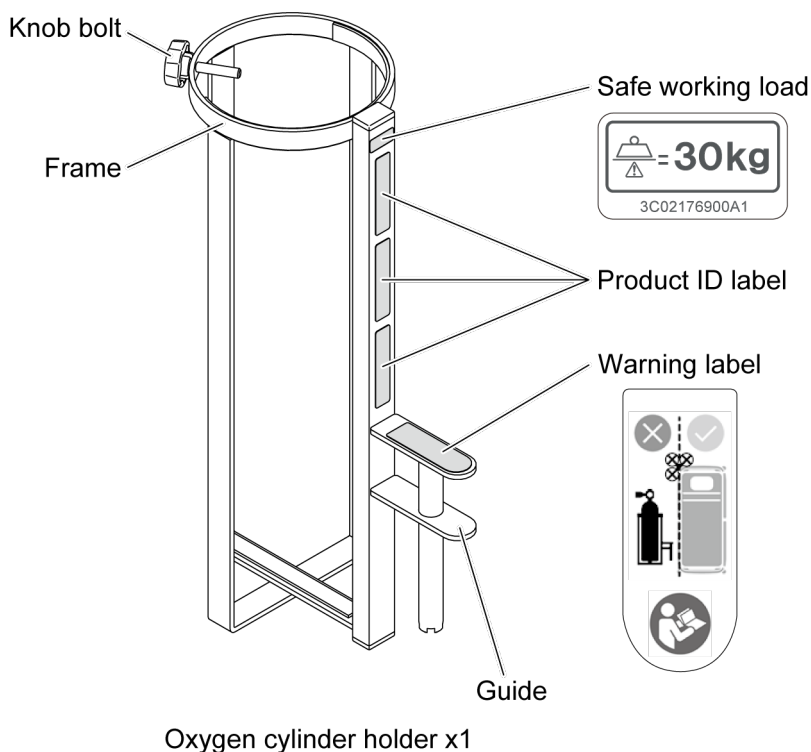

Oxygen cylinder holder x1

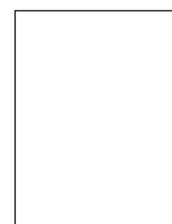

Instruction manual  
(this document) x1

# SAFETY PRECAUTIONS

 <b>WARNING</b>	Indicates that improper handling by ignoring this indication may cause death or serious injury (broken bones, pressure, or paralysis).
--	--

■ **The oxygen cylinder holder should be attached to a medical device to be used together with this product designated by Paramount Bed.**

Combined use with a non-designated or third-party medical device may cause an accidental injury, or the oxygen cylinder holder or the oxygen cylinder may be damaged or deformed. For suitable products, contact Paramount Bed (see P.8).

■ **Do not put your foot or any object under the oxygen cylinder holder.**

When adjusting the medical device height or inclination angle, your foot may get caught in the gap between the oxygen cylinder holder and the floor, resulting in injury, or the object may be damaged or deformed.

■ **Before use, make sure that the knob bolt is firmly tightened.**

If it is not tightened enough, the oxygen cylinder may be unstable and oxygen supply may be interrupted.

■ **Attach the oxygen cylinder holder to any of the accessory attachment holes located on the two corners of head end of the medical device.**

If you insert the oxygen cylinder holder into a hole other than the accessory attachment hole, the oxygen cylinder holder may detach and fall on your foot during medical device operation, resulting in injury, or the oxygen cylinder holder or the medical device may be damaged or deformed.

■ **Do not attach the oxygen cylinder holder to the foot end of medical device.**

When the medical device is operated with reverse trendelenburg, there is a risk that the foot may be caught between the oxygen cylinder holder and the floor.

■ **Do not repair or modify by yourself.**

Doing so may create an unintended gap, resulting in accidental injury.

■ **When using the oxygen cylinder, use caution not to allow the flowmeter, etc. to come into contact with a person or object around the medical device to be used together with this product.**

If a contact happens, the flowmeter or the oxygen cylinder holder may be damaged, resulting in injury.

■ **Stop use in case of a failure, damage, or deformation.**

In case of a failure, damage, or deformation, immediately stop use and contact Paramount Bed (see P.8) or your distributor for repair or replacement. You may accidentally injure yourself.

■ **Inspect the oxygen cylinder holder regularly.**

To ensure safety, inspect the product regularly, at least once a year. The product wears out and deteriorates depending on the frequency of use and the environment. Regularly inspect for loose parts and damage. If you use a worn or deteriorated oxygen cylinder holder, you may accidentally injure yourself.

 <b>CAUTION</b>	Indicates that improper handling by ignoring this indication may cause minor injuries (such as bruises, scratches, or cuts) or property damage.
--	---

■ **Do not move the medical device to be used together with this product while holding the oxygen cylinder holder.**

Excessive force may be applied to the oxygen cylinder holder, causing damage or deformation.

# USING THE PRODUCT

 <b>WARNING</b>	<ul style="list-style-type: none"><li>• Attach the oxygen cylinder holder to any of the accessory attachment holes on the two corners of head end of the medical device. If you attach the oxygen cylinder holder to a hole other than the accessory attachment hole, the oxygen cylinder holder may detach and fall on your foot during medical device operation, resulting in injury, or the oxygen cylinder holder or the medical device may be damaged or deformed.</li><li>• Before use, make sure that the knob bolt is firmly tightened. If it is not tightened enough, the oxygen cylinder may be unstable and oxygen supply may be interrupted.</li><li>• When using the oxygen cylinder, use caution not to allow the flowmeter, etc. to come into contact with a person or object around the medical device. If a contact happens, the flowmeter or the oxygen cylinder holder may be damaged, resulting in injury.</li></ul>
--	--

Attach the oxygen cylinder holder to any of the accessory attachment holes on the two corners of head end of the medical device (see the figure below).



**Be sure to use a 1,000 L to 1,500 L oxygen cylinder (from 14 cm to 15.5 cm in diameter).**

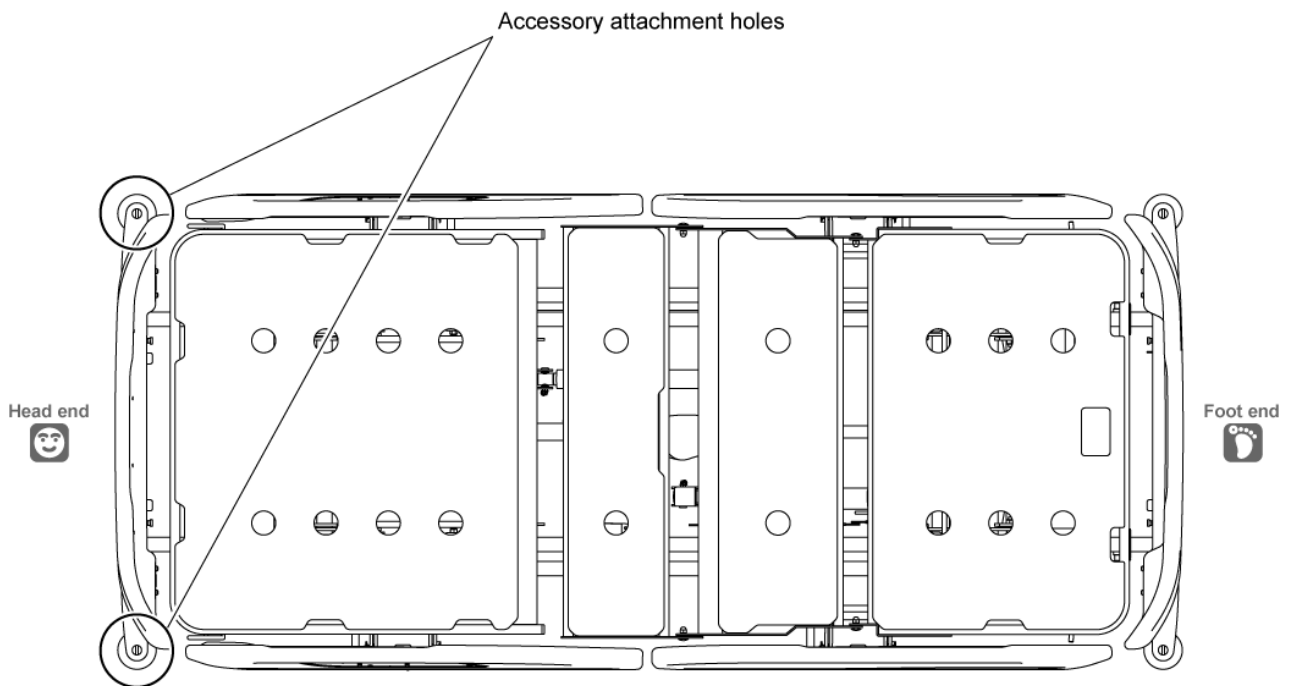

Accessory attachment hole

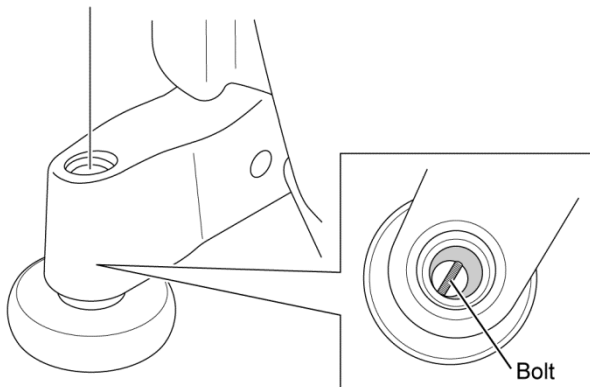

1. Insert the oxygen cylinder holder into any of the optional accessory attachment holes on the two corners of head end of the medical device.



WARNING

**Do not attach the oxygen cylinder holder to the foot end of medical device. When the medical device is operated with reverse trendelenburg, there is a risk that the foot may be caught between the oxygen cylinder holder and the floor.**

2. Align a groove of the oxygen cylinder holder with the bolt in the bottom of the optional accessory attachment hole.

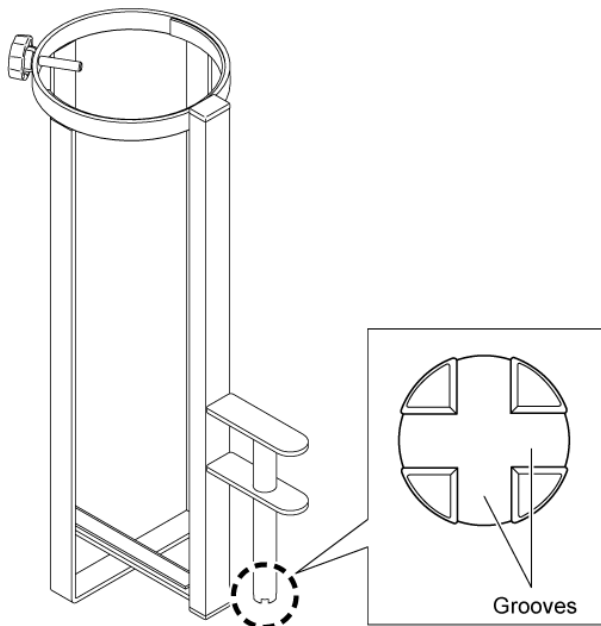

WARNING

- Use the oxygen cylinder holder at position A in the figure on the left. If used in position B or C, the medical device may become unstable, fall over, and cause injury.
- Do not install the IV pole on the right side (left side) of the medical device when using the oxygen cylinder holder on the right side (left side) of the medical device. If used in one side of the medical device, the medical device may become unstable, fall over, and cause injury.

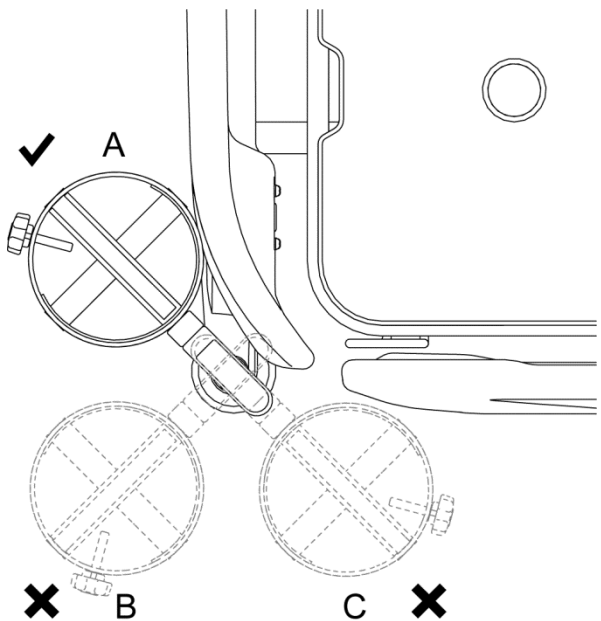

# USING THE PRODUCT

---

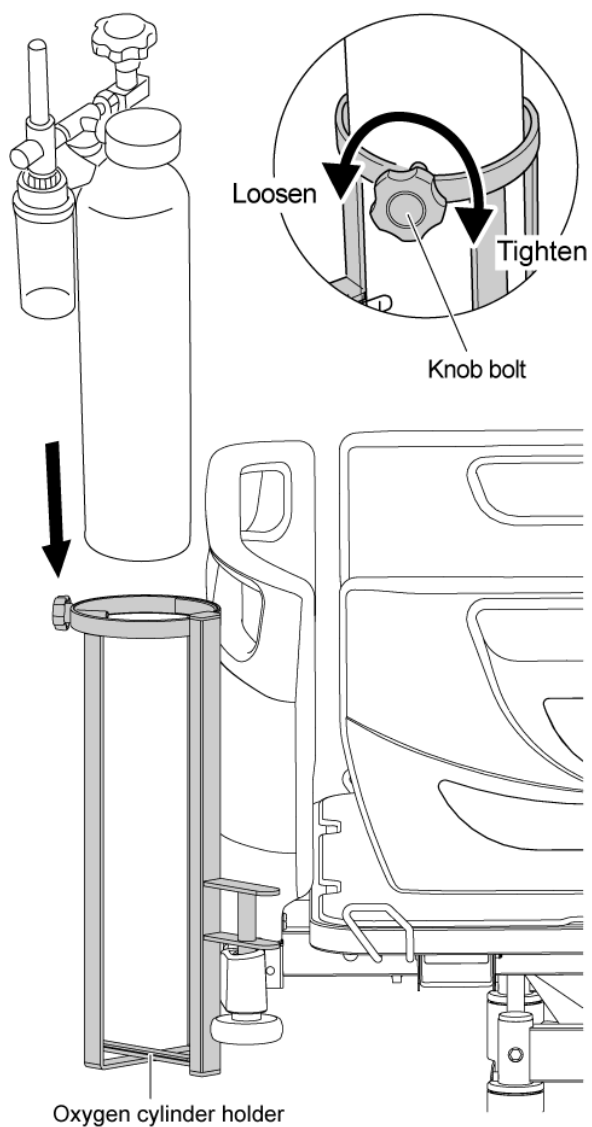

3. Turn the knob bolt on the oxygen cylinder holder counterclockwise to loosen it.
4. Slowly insert the oxygen cylinder into the oxygen cylinder holder and then turn the knob bolt clockwise to tighten it and firmly secure the oxygen cylinder.
5. Gently shake the oxygen cylinder to make sure that it does not wobble.

# DAILY MAINTENANCE, LONG-TERM STORAGE, AND PRODUCT DISPOSAL

## Daily maintenance

### When removing stains from parts

Perform steps 1 to 5 below.

1. Wipe off stains with a cloth soaked in a neutral detergent diluted with water and wrung out well.
2. Wipe off any residual detergent with a cloth soaked in water and wrung out well.
3. Wipe away any leftover moisture with a dry cloth.
4. At the conclusion of cleaning, visually inspect all surfaces of the oxygen cylinder holder.
5. If not visually clean, repeat cleaning the cleaning procedure.



**If the oxygen cylinder holder cannot be visually cleaned, the oxygen cylinder holder should be discarded.**

### When disinfecting parts

Use one of the disinfectants listed below at the specified concentrations by following the instructions in the instruction manual for the disinfectant.

76.9% - 81.4% Ethanol for disinfection

0.05% - 0.2% Benzalkonium chloride (e.g., Osvan)

0.05% - 0.2% Benzethonium chloride (e.g., Hyamine)

0.05% Chlorhexidine gluconate (e.g., Hibitane)

0.02% - 1.0% Sodium hypochlorite (e.g., Milton)

\* We recommend to disinfect the oxygen cylinder holder before use by another patient.



**CAUTION**

- Do not use volatile cleaning solutions (such as paint thinner, benzene, or gasoline) or cresol. Discoloration or deterioration may result.
- Do not use disinfectants other than those listed above. Damage or deterioration may result.
- Thoroughly wipe off parts with a damp cloth after using a neutral detergent. Not doing so may cause cracking of the resin.



- If the oxygen cylinder holder is stained, wipe off promptly. Leaving it as is may cause permanent stains.
- An ozone sterilizer, autoclave, bed cleaning machine, etc. cannot be used for the oxygen cylinder holder.
- Do not sterilize. The oxygen cylinder holder is not intended for sterilization and has not been tested for compatibility with healthcare sterilization systems including ozone, moist heat/steam, dry heat, ethylene oxide vaporized Hydrogen peroxide and other chemical sterilizers. Exposure of the oxygen cylinder holder to these processes may damage the oxygen cylinder holder and render it non-functional.

## Long-term storage

- Avoid a location subject to high temperature or humidity, low temperature, dryness or excessive dust. Store the oxygen cylinder holder at a temperature between -10°C and 50°C, and humidity between 30% RH and 90% RH.
- Keep the instruction manual in a safe place so that it does not become lost.

## Disposal

When disposing of the product, observe the local rules and regulations.

# SPECIFICATIONS AND PRODUCT SYMBOL DEFINITIONS

## Specifications

<b>Product name</b>	<b>Oxygen cylinder holder</b>
<b>Model No.</b>	<b>IC-A84</b>
Dimensions	29.9 x 16.5 x 51.9 cm
Product weight	3.5 kg
Materials	Made of steel, zinc and aluminum coating
Outside diameter of usable oxygen cylinder	1000 to 1500 L (14 cm to 15.5 cm)
Safe working load	30 kg















## Classification and Standards

Classification as medical device in Europe : Class 1

Safety standards applied : Since this device is an accessory, for safety standards applied on this device, refer to the instruction manual of the suitable medical devices.

## Product symbol definitions

The following symbols are used for this product.

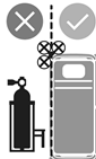
Symbol	Description	Symbol	Description
	Serial number		Authorised representative in the european community * Either of the symbols is used.
	Model number		
	Lot number		CE mark
	Manufacturer * It may be called "Legal Manufacturer" or "Brand Owner" etc. * This symbols is not applicable in the country of origin.		See the instruction manual
	<ul style="list-style-type: none"> <li>Country of manufacture (Made in India)</li> <li>Manufacturing site * In the country of origin, the site acts as the manufacturer.</li> <li>Date of manufacture (YYYY-MM-DD)</li> </ul>		Refer to the instruction manual
	Medical device (This product is an accessory for medical devices and such accessory is required to be labeled as "Medical Device" under medical device regulations in Europe.)		Safe working load
 	Unique Device Identifier This is a 2D Code (GS1 DataMatrix) that encodes the UDI (Unique Device Identifier) required by the Unique Device Identification System designed to adequately identify devices through distribution and use.		Use in the correct position

# AFTER SALE SERVICE

## 1. When requesting repairs

For requests for repair, contact Paramount Bed (see Contact Information below) or your distributor.

### Information required when you request repair



- Product name, model number, and product ID label number (for the affixed location, see “Part names and checking parts”)
- Date of purchase
- Details of failure or problem (provide as much detail as possible)
- Facility name, your name, address, and phone number

The minimum retention period of service functional parts (required to maintain the original functions of products) is 8 years after discontinuation of manufacturing.

## 2. When you are not sure about the after-sales service

For any queries, please feel free to contact your distributor or to the following address.

### Contact information

Location in Japan (Manufacturer)	Location in India (Manufacturing premises)
 PARAMOUNT BED CO., LTD. 14-5, 2-chome, Higashisuna, Koto-ku, Tokyo, 136-8670 , Japan TEL: +81-(0)3-3648-2961 FAX: +81-(0)3-3648-5781	 PARAMOUNT BED INDIA PVT. LTD. Plot Number 430, Sector 8, IMT Manesar, 122050 Gurugram, Haryana, INDIA TEL: +91-124-4205748

For any queries, contact to the address or telephone number listed below or your distributor.

For other contact information, please visit the website.

Website: <https://www.paramount.co.jp/english/>



# MEMO

---



